

SPX®

Refrigerated Air Dryers

TXK · HXK Series

Refrigerated Air Dryers

SPX®

TXK · HXK Series



SPX FLOW TECHNOLOGY KOREA CO., LTD.

HEADQUARTERS / MAIN FACTORY

13-104, Nonggong-gil, Jeongwan-myeon, Gijang-gun, Busan, 619-961, Korea
TEL.82-51-728-5360, FAX.82-51-728-5359

2nd FACTORY

79, Sandan 5-ro, Jeongwan-myeon, Gijang-gun, Busan, 619-961, Korea
TEL.82-51-726-0231, FAX.82-51-727-5340

SEOUL OFFICE

(KT Bldg., Yeouido-dong) 14, Yeouidae-ro, Yeongdeungpo-gu, Seoul, 150-931, Korea
TEL.82-2-6297-4000 FAX.82-2-783-0160

www.spflowkorea.com

ft.korea@spx.com

Some specifications in this bulletin may change without notice.

Refrigerated Air Dryers

TXK Series

15~50 scfm

Research indicates that many customers want reliability and dry compressed air at an affordable price. No fancy bells and whistles—just dry air, pure and simple. The TXK series non-cycling dryers were designed to meet these demands.

Feature

Static condenser with no cooling fan

- ▶ Worldwide-patented product
- ▶ No maintenance required
- ▶ Excellent quiet operation
- ▶ Lowest operating cost

Perfect application for indoor installation such as hospital and laboratory

Robust design & compact size

Unique refrigerant control system

- ▶ Air-to-refrigerant reheating system

Energy saving through waste heat recovery

- ▶ No condensate on outlet pipe

Excellent dew point performance under all conditions



Jemaco Refrigerated Air Dryers

Compressed air users around the world have relied on Jemaco to provide innovative compressed air treatment solutions for critical applications. Jemaco maintains a long standing reputation for manufacturing products that deliver superior performance, time proven reliability and optimal energy savings. Jemaco is the preferred choice for providing clean, dry compressed air for the most challenging industries.

Compressed air contains ingested and generated contamination in the form of solid particulate, extraneous oils and water vapor. If untreated, the air will adversely affect pneumatically operated components and equipment. Jemaco refrigerated air dryers are recognized for reliable, effective and efficient contaminant removal systems.

About SPX

Based in Charlotte, NC, USA, SPX Corporation is a global Fortune 500 multi-industry manufacturing leader with over \$5 billion in annual revenue, operations in more than 35 countries and approximately 15,000 employees. The company's highly-specialized, engineered products and technologies are concentrated in Flow Technology and energy infrastructure.

www.spx.com

How it works

Warm saturated air enters the evaporator where it is cooled by refrigerant being controlled by a constant pressure expansion valve. Water vapor condenses into a liquid for removal at the moisture separator by a drain. The cold, dry air is reheated as it passes through the reheater. This prevents dryer outlet air pipeline sweating. The static condenser eliminates the need for a cooling fan and simplifies the system.

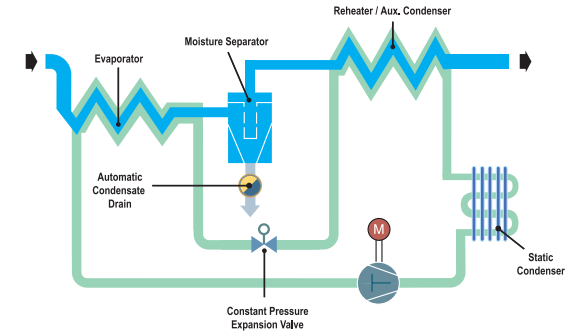

TXK Series Specification

Model	Flow Capacity (Nm ³ /min)	Unit (kW)	Power Supply	Inlet/Outlet Connections (PT)	Weight (kg)	Dimensions (mm)			Refrigerants
						H	W	D	
TX15K	0.50	0.24	220~240V 1PH 50Hz	3/8"	20	382	320	320	R-134a
TX25K	1.00	0.34		3/4"	32	568	368	394	
TX35K	1.33	0.42		3/4"	32	568	368	394	
TX50K	1.67	0.58		3/4"	44	568	500	500	

* Rating Conditions: 42°C inlet temperature, 7.0 barG inlet pressure, 100% relative humidity, 35°C ambient temperature.

* Maximum/minimum inlet pressure: 16 barG/2 barG, Maximum/minimum inlet air temperature: 60°C/4°C, Maximum/minimum ambient air temperature: 43°C/2°C

Capacity Correction Factor

Inlet Air Pressure (barG)

barG	4	5	6	7	8	9	10	11	12
Factor	0.82	0.88	0.95	1.00	1.05	1.09	1.13	1.16	1.18

Inlet Air Temperature (°C)

°C	30	35	40	42	45	50	55	60
Factor	1.77	1.36	1.08	1.00	0.89	0.74	0.62	0.52

Ambient Air Temperature (°C)

°C	20	25	30	35	40	45	50
Factor	1.20	1.13	1.07	1.00	0.94	0.85	0.74

Frequency (Hz)

Hz	50	60
Factor	1.00	1.20

Example: What is the capacity of a 6.67 Nm³/min model when the compressed air at the inlet to the dryer is 10 barG and 45°C and ambient temperature is 35°C?

Answer: 6.67 Nm³/min (rated flow from Product Specifications Table) x 1.08 (correction factor for inlet pressure from Table 1) x 0.68 (correction factor for inlet temperature from Table 2) x 0.88 (correction factor for ambient temperature from Table 3) = 4.31 Nm³/min

Refrigerated Air Dryers

HXK Series

75~600 scfm

The HXK series utilizes advanced heat exchanger, separation and refrigeration technology. It's a revolutionary that uses an innovative, simplified refrigeration circuit to provide dependable operation, low operating cost and versatile installation. Performs in rated conditions of 75 to 600 scfm.

Feature

3-in-1 stainless steel brazed plate heat exchanger with integral separator ensures optimal dew point performance under all conditions

Compact design uses 40% less floor space

Low pressure drop reduces operating costs

User friendly controller

- ▶ Power-on LED, Compressor-on LED, On/Off rocker switch and dew point bar graph LED display

Reliable timed electric drain with push-to-test button on the front panel

Electro-galvanized steel cabinet with two part epoxy coating

- ▶ Providing long term corrosion resistance

Environmentally friendly R-134a and R-407C refrigerants



Optional

No loss drain valve

Stainless Steel Brazed Plate Heat Exchanger

5 Year Warranty Program Provided

Integral structure

- ▶ Air-to-air heat exchanger, evaporator & moisture separator

High & consistent quality (counter-current flow)

Larger heat transfer surface area

Consistent dew point

Minimized air pressure drop due to the minimum piping

No moisture carry over

Patented design

- ▶ USA, EU, China, Japan, Korea



How it works

Warm, saturated compressed air enters the air-to-air heat exchanger and is cooled by the exiting air. The precooled air then enters the air to refrigerant heat exchanger and is further chilled causing water vapor to condense. Condensed moisture is collected from the air stream by an integral separator with stainless steel demister. Liquid condensate is removed from the separator by an automatic timed electric drain. Cold air is then reheated in the air-to-air heat exchanger to eliminate pipe line sweat. Clean, dry air exits the dryer and is now conditioned for use.

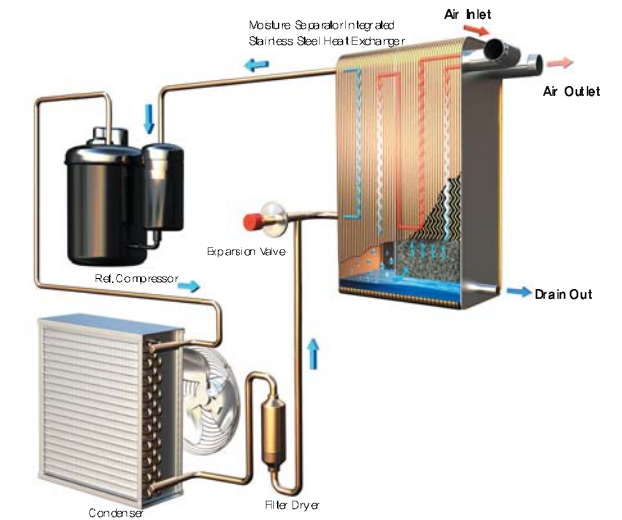

HXK Series Specification

Model	Flow Capacity (Nm ³ /min)	Unit (kW)	Power Supply	Inlet/Outlet Connecions (PT)	Weight (kg)	Dimensions(mm)			Refrigerants
						H	W	D	
HX76K	2.50	0.58	220~240V 1PH 50Hz	1"	50	601	363	861	R-134a
HX101K	3.00	0.60		1"	53	601	363	861	
HX151K	4.92	0.87		1"	58	601	363	921	
HX201K	6.67	1.39		2"	78	761	443	971	R-407C
HX251K	8.00	1.58		2"	85	761	443	971	
HX351K	10.08	2.06		2"	100	811	493	1151	
HX426K	13.33	2.61		2"	112	811	493	1151	
HX500K	15.00	2.82	2"	134	811	493	1251		
HX601K	18.02	3.40	380~420V 3PH 50Hz	2 1/2"	152	811	543	1321	

* Rating Conditions : 35°C inlet temperature, 7.0 barG inlet pressure, 100% relative humidity, 25°C ambient temperature.

* Maximum/minimum inlet pressure : 16.0 barG/3 barG, Maximum/minimum inlet air temperature : 49°C/4°C, Maximum/minimum ambient air temperature : 43°C/4°C

* Models for the high temperature condition are optional, consult factory.

Capacity Correction Factor

Inlet Air Pressure (barG)

barG	4	5	6	7	8	9	10	11	12
Factor	0.87	0.92	0.96	1.00	1.03	1.07	1.10	1.12	1.14

Inlet Air Temperature (°C)

°C	30	35	40	45	49
Factor	1.22	1.00	0.84	0.71	0.60

Ambient Air Temperature (°C)

°C	20	25	30	35	40	43
Factor	1.06	1.00	0.92	0.85	0.78	0.72

Frequency (Hz)

Hz	50	60
Factor	1.00	1.20

Example : What is the capacity of a 6.67 Nm³/min model when the compressed air at the inlet to the dryer is 10 barG and 45°C and ambient temperature is 35°C?

Answer : 6.67 Nm³/min (rated flow from Product Specifications Table) x 1.08 (correction factor for inlet pressure from Table 1) x 0.68 (correction factor for inlet temperature from Table 2) x 0.88 (correction factor for ambient temperature from Table 3) = 4.31 Nm³/min

Refrigerated Air Dryers

HXK Series

800~12000 scfm

The HXK series, built-in with our highly advanced stainless steel plate heat exchanger, defers refrigeration load with great efficiency of heat-exchanging. Saving in electrical power and convenient in maintenance are its unique feature.

Feature

Stainless steel brazed plate heat exchanger

- ▶ No rust water and corrosion
- ▶ One-pass structure : Heat exchanger and reheater

Automatically adapts to system needs

Fully automatic operation saves money

Every unit comes pre-assembled with quality components

User friendly controller

- ▶ Power-on LED, Compressor-on LED, On/Off rocker switch and dew point bar graph LED display

Reliable timed electric drain with push-to-test button on the front panel

Electro-galvanized steel cabinet with two part epoxy coating

- ▶ Providing long term corrosion resistance

Environmentally friendly R-407C refrigerant

No loss drain valve (Optional)

Optional / SCMI (System Control Monitor II)

LCD main window displays

- ▶ Dryer run, Auto drain valve on, Fan motor on, Alarm

LCD monitor displays

- ▶ Inlet, Ambient/Cooling water, Chiller inlet & discharge refrigerant temperatures, Discharge refrigerant temperatures

Membrane touch panel

Programmable timer drain settings



How it works

Saturated incoming compressed air is quickly chilled in the air-to-air heat exchanger by the cold compressed air as it exits the air-to-refrigerant (evaporator). Here, the cold, dry air is reheated to prevent pipeline sweating and reduce compressor energy before exiting the dryer. In the evaporator, the air temperature is reduced to that of the cold refrigerant. A moisture separator lowers the velocity and mechanically separates the condensate from the air stream. An automatic drain removes the condensate. The air-to-air heat exchanger re-heats the air and clean, dry compressed air exits the dryer.

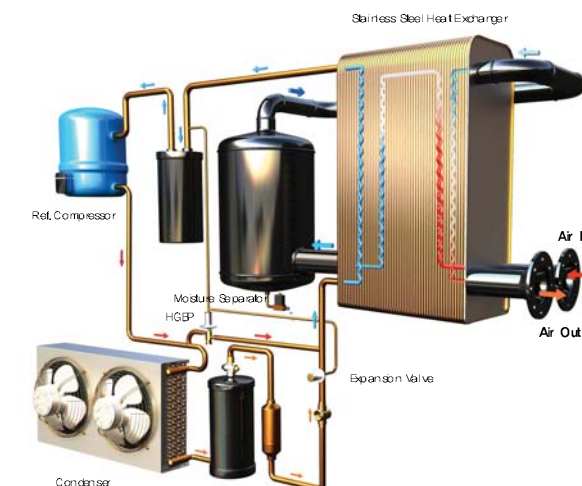

HXK Series Specification

Model	Flow Capacity (Nm ³ /min)	Unit (kW)	Power Supply	Inlet/Outlet Connections (FLG)	Weight (kg)	Dimensions(mm)			Refrigerants
						H	W	D	
HX800K	24.06	4.5	380~420V 3PH 50Hz	3"	385	1470	750	1400	R-407C
HX1050K	31.48	6.1		4"	400	1470	750	1400	
HX1250K	37.52	7.6		4"	440	1470	750	1400	
HX1500K	45.10	8.6		4"	850	1582	860	1600	
HX2000K	60.00	9.5		6"	1000	1628	1050	1800	
HX2500K	75.00	10.3		6"	1050	1628	1050	1800	
HX3000K	90.10	11.8		6"	1100	1628	1050	1800	
HX4000K	120.00	15.1		8"	2000	2320	1500	2850	
HX5000K	150.10	20.8		8"	2300	2320	1500	2850	
HX6000K	180.30	25.7		8"	2500	2320	1500	2850	
HX8000K	240.10	38.5		8"	3500	2320	1500	3800	
HX10000K	300.30	46.6		10"	4800	2400	1600	4800	
HX12000K	360.30	52.7	10"	5000	2400	1600	4800		

* Rating Conditions : 35°C inlet temperature, 7.0 barG inlet pressure, 100% relative humidity, 25°C ambient temperature.

* Maximum/minimum inlet pressure : 12.1 barG/3 barG, Maximum/minimum inlet air temperature : 49°C/4°C, Maximum/minimum ambient air temperature : 43°C/4°C

* Dimension is for air-cooled condenser type. Water-cooled condenser type is available, consult factory.

* Models for the high temperature condition are optional, consult factory.

Capacity Correction Factor

Inlet Air Pressure (barG)

barG	4	5	6	7	8	9	10	11	12
Factor	0.87	0.92	0.96	1.00	1.03	1.07	1.10	1.12	1.14

Inlet Air Temperature (°C)

°C	30	35	40	45	49
Factor	1.22	1.00	0.84	0.71	0.60

Ambient Air Temperature (°C)

°C	20	25	30	35	40	43
Factor	1.06	1.00	0.92	0.85	0.78	0.72

Frequency (Hz)

Hz	50	60
Factor	1.00	1.20

Example : What is the capacity of a 6.67 Nm³/min model when the compressed air at the inlet to the dryer is 10 barG and 45°C and ambient temperature is 35°C?

Answer : 6.67 Nm³/min (rated flow from Product Specifications Table) x 1.08 (correction factor for inlet pressure from Table 1) x 0.68 (correction factor for inlet temperature from Table 2) x 0.88 (correction factor for ambient temperature from Table 3) = 4.31 Nm³/min